



## ARRL Periodicals Archive – Search Results

### A membership benefit of ARRL and the ARRL Technical Information Service

**ARRL Members:** You may print a copy for personal use. Any other use of the information requires permission (see Copyright/Reprint Notice below).

**Need a higher quality reprint or scan?** Some of the scans contained within the periodical archive were produced with older imaging technology. If you require a higher quality reprint or scan, please contact the ARRL Technical Information Service for assistance. Photocopies are \$3 for ARRL members, \$5 for nonmembers. For members, TIS can send the photocopies immediately and include an invoice. Nonmembers must prepay. Details are available at [www.arrl.org/tis](http://www.arrl.org/tis) or email [photocopy@arrl.org](mailto:photocopy@arrl.org).

**QST on CD-ROM:** Annual CD-ROMs are available for recent publication years. For details and ordering information, visit [www.arrl.org/qst](http://www.arrl.org/qst).

**Non-Members:** Get access to the ARRL Periodicals Archive when you join ARRL today at [www.arrl.org/join](http://www.arrl.org/join). For a complete list of membership benefits, visit [www.arrl.org/benefits](http://www.arrl.org/benefits).

### Copyright/Reprint Notice

In general, all ARRL content is copyrighted. ARRL articles, pages, or documents--printed and online--are not in the public domain. Therefore, they may not be freely distributed or copied. Additionally, no part of this document may be copied, sold to third parties, or otherwise commercially exploited without the explicit prior written consent of ARRL. You cannot post this document to a Web site or otherwise distribute it to others through any electronic medium.

For permission to quote or reprint material from ARRL, send a request including the issue date, a description of the material requested, and a description of where you intend to use the reprinted material to the ARRL Editorial & Production Department: [permission@arrl.org](mailto:permission@arrl.org).

**QST Issue:** Sep 1957

**Title:** Third Method of S.S.B., The

**Author:** Howard F. Wright, Jr., W1PNB

[Click Here to Report a Problem with this File](#)

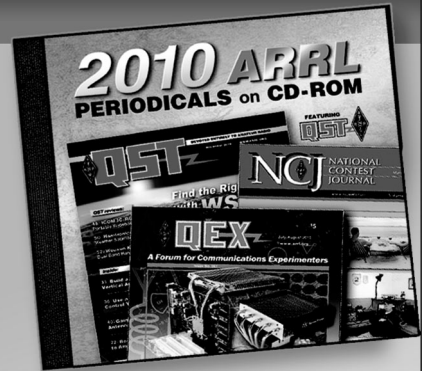

## 2010 ARRL Periodicals on CD-ROM

ARRL's popular journals are available on a compact, fully-searchable CD-ROM. Every word and photo published throughout 2010 is included!

- **QST** The official membership journal of ARRL
- **NCJ** National Contest Journal
- **QEX** Forum for Communications Experimenters

**SEARCH** the full text of every article by entering titles, call signs, names—almost any word. **SEE** every word, photo (including color images), drawing and table in technical and general-interest features, columns and product reviews, plus all advertisements. **PRINT** what you see, or copy it into other applications.

**System Requirements:** Microsoft Windows™ and Macintosh systems, using the industry standard Adobe® Acrobat® Reader® software. The Acrobat Reader is a free download at [www.adobe.com](http://www.adobe.com).

### 2010 ARRL Periodicals on CD-ROM

ARRL Order No. 2001

**Only \$24.95\***

\*plus shipping and handling

Additional sets available:

2009 Ed., ARRL Order No. 1486, \$24.95  
 2008 Ed., ARRL Order No. 9406, \$24.95  
 2007 Ed., ARRL Order No. 1204, \$19.95  
 2006 Ed., ARRL Order No. 9841, \$19.95  
 2005 Ed., ARRL Order No. 9574, \$19.95  
 2004 Ed., ARRL Order No. 9396, \$19.95  
 2003 Ed., ARRL Order No. 9124, \$19.95  
 2002 Ed., ARRL Order No. 8802, \$19.95  
 2001 Ed., ARRL Order No. 8632, \$19.95



**ARRL** The national association for AMATEUR RADIO™

SHOP DIRECT or call for a dealer near you.  
 ONLINE [WWW.ARRL.ORG/SHOP](http://WWW.ARRL.ORG/SHOP)  
 ORDER TOLL-FREE 888/277-5289 (US)



- 4) Undesired signal components are at least 30 db. down.
- 5) The s.s.b. signal can be generated at any desired radio frequency.
- 6) Operation can be bilateral; that is, the method also can be used for s.s.b. reception.
- 7) Quality is good.
- 8) The unit can be small and rugged.

Fig. 2 shows the speech spectrum to be applied to the system. These frequencies heterodyne



Fig. 2 — Speech spectrum considered in the system described.

(modulate) with the 1800-cycle first carrier in each initial modulator. Except for the quadrature phase shift, the outputs of both modulators are identical. For the present we need consider only one.

**First Modulator and Low-Pass Filter**

Fig. 3 shows the output spectrum of either

initial modulator. Notice that the upper side band of this modulation process (sum frequency)

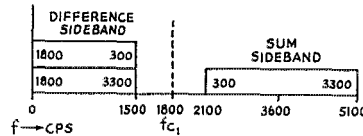

Fig. 3 — Output spectrum of first balanced modulator.

occupies a conventional relation to the 1800-cycle carrier,  $f_{c1}$ . The lower side band (difference frequency) is folded upon itself. This occurs because there can be no "minus frequencies" and because the carrier is within the speech range. For the latter reason there are two speech frequencies — one above, and one below 1800 cycles — which mix to produce identical frequencies in the modulator output range of 0 to 1500 cycles. This is shown graphically in Fig. 4. Here, each frequency in the difference side band may represent either of two original audio frequencies. The exception is 0 cycles (d.c.), which now represents

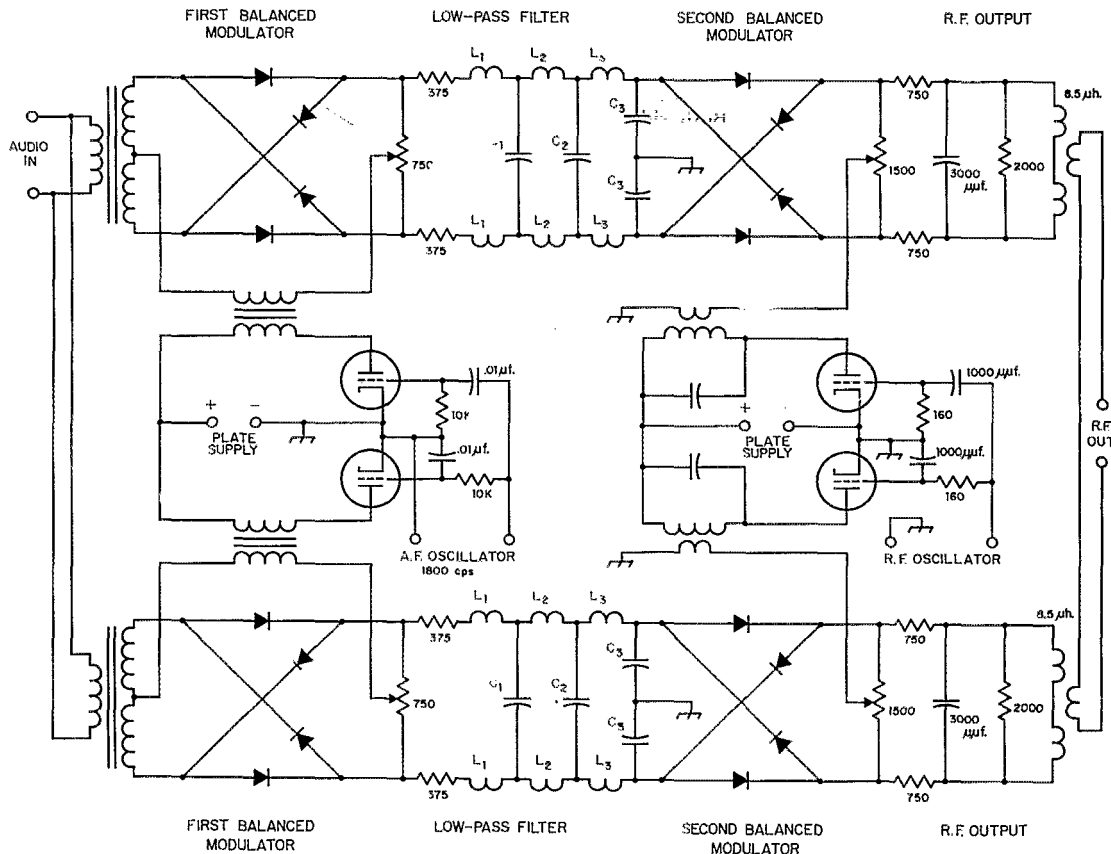

Fig. 1 — Circuit of the "third method" single-side-band generator (Weaver, *Proc. IRE*, December, 1956). Constants of output circuits of second balanced modulators (3000  $\mu\mu\text{f.}$  and 8.5  $\mu\text{h.}$ ) and the RC values in the r. f. oscillator phase-shift network (160 ohms and 1000  $\mu\mu\text{f.}$ ) are for an output frequency of 1 Mc. and should be modified appropriately for other output frequencies. Low-pass filter constants are as follows:

$C_1$  — 0.15  $\mu\text{f.}$      $C_2$  — 0.20  $\mu\text{f.}$      $C_3$  — 0.11  $\mu\text{f.}$      $L_1$  — 27.5 mh.     $L_2$  — 100 mh.     $L_3$  — 75 mh.

original audio of 1800 cycles. Referring to Fig. 1, notice that d.c. coupling is used between first and second modulators so that audio information at and around 1800 cycles will not be destroyed.

Referring again to Fig. 3, we are interested only in the difference side band — below 1500 cycles. The sum side band — above 2100 cycles — must be effectively removed. If it is not removed this band of frequencies will appear in the final signal as a normal, readable, unfolded, “unwanted side band.”

The dashed line in Fig. 5 represents the low-pass filter requirements necessary for an arbitrary 40-db. suppression of out-of-channel unwanted side band if the speech range starts at 300 cycles.

### Second-Modulator Operation

The output spectrum passed by the filter is applied to the second modulator. In this case (the second modulator) the carrier is at approximately the desired output frequency. Quadrature phase is also maintained between the carrier voltages applied to both second modulators.

Fig. 6 is the individual output of either second modulator. The signal at this point is a double-side-band suppressed-carrier signal. Both side bands are 1500 cycles wide. However, all 3000 cycles of original audio information is contained in each of these side bands because of the folding effect of the first modulator. Both side bands contain two components. One represents the low half of the original speech and the other, the high.

Both modulators have this same output spectrum. The phase relationship of the individual outputs, due to the quadrature carrier supply to both modulators, is such that combining the outputs of the second modulators results in one component being phased out of each side band. Thus, in Fig. 6, the signal components contained in the shaded areas will be suppressed and those in the clear areas transmitted; or, if either the

audio or r.f. phase is reversed, the opposite will be true. If the components in the unshaded areas are transmitted, an s.s.b. receiver tuned to a synthetic carrier frequency of  $f_{c2} + 1800$  will reproduce a normal audio spectrum. If the components in the shaded areas are used, the receiver would switch side bands and tune to  $f_{c2} - 1800$  for proper demodulation.

Fig. 7 demonstrates the first case and shows the presence and location of the folded-back, unwanted side band. This “unwanted” is due to imperfect phasing. It occupies the same channel as the “wanted.”

### Operating Characteristics

Fig. 8 is the complete output spectrum of the final signal. If the receiver is set at  $f_{c2} - 1800$  or  $f_{c2} + 1800$  (depending on the side band transmitted), proper reception of the original audio will result. Any unbalance in the second modulators resulting in leakage of the true suppressed carrier at  $f_{c2}$  will result in an audible 1800-cycle

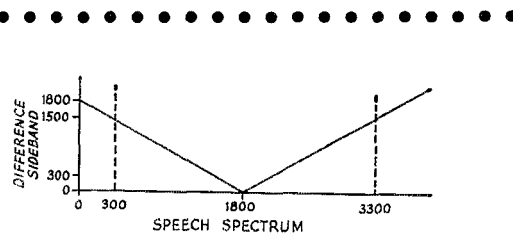

Fig. 4

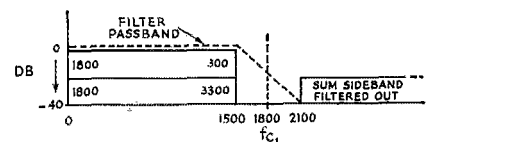

Fig. 5

Fig. 4 — Frequency components in the speech band that are spaced equally either side of 1800 cycles are converted to the same frequency in the difference side band. This occurs in the first balanced modulator.

Fig. 5 — Audio-frequency filter characteristic for 40-db. suppression of out-of-band components.

Fig. 6 — The signal channel contains two sets of components, corresponding to an upper side band (shaded) or lower side band (clear). One set can be eliminated by the r.f. and audio phasing. The receiver local oscillator frequency is set 1800 cycles to one side of the suppressed transmitter carrier frequency. The side to be used depends on the side band transmitted.

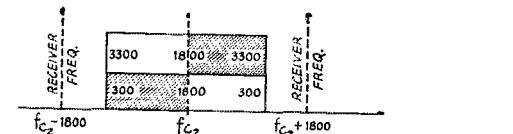

Fig. 6

Fig. 7 — An error in phasing results in an inverted side band superimposed on the desired side-band signal.

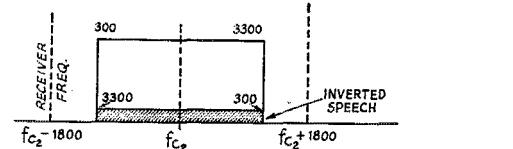
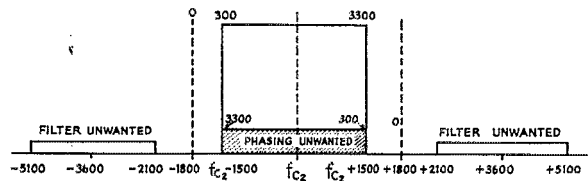

Fig. 7

Fig. 8—Complete spectrum of the signal, showing the positions of out-of-band unwanted components not suppressed by the low-pass audio filters.



tone. Notice that the out-of-channel groups marked "filter unwanted" are a function of filter performance. The shaded area indicating in-channel inverted signal is a function of phasing adjustment.

Single-frequency steady signals that tune like carriers will appear at  $f_{c2} - 1800$  and  $f_{c2} + 1800$  (the spots of proper receiver tuning) if the original audio frequency carrier at 1800 cycles is not perfectly nulled out in the first pair of balanced modulators.

The novel features of the "third method" aroused considerable interest among my s.s.b. friends. There was much speculation as to how the system would work and sound. Accordingly, having tried everything from n.f.m. to "super-modulation," I decided to give the "third method" a try. Because of uncertainty as to the outcome and a desire for cheap, speedy results, I didn't build a complete exciter but just a basic unit which could be connected to an existing exciter. The results are shown in the photograph. Since the parts were largely "scrounged" from interested bystanders and any part that would work, regardless of size or shape, was used, no conclusion as to the possibilities of the system in terms of bulk or com-

plexity should be drawn from the picture.

The basic circuit was followed closely. Minor changes included changing the crystal diodes to tubes, moving the output frequency to 455 kc., and changing the phase splitter of the second oscillator to critically-coupled tuned circuits. A dual-triode audio stage is followed by a low-pass audio filter and circuitry to attenuate lows. The 1800-cycle oscillator uses a toroid-wound inductance. The transformers supplying audio are 500-ohm line-to-line, and plate-to-line transformers supply 1800-cycle carrier. The output tuned circuits were scaled down to 455 kc.

When complete, the unit was coupled into the i.f. stages of the existing 20-ke. filter rig. The resulting signal was examined and adjustments made using the highly selective station receiver, calibrated attenuator, and oscilloscope which have been used for several years to accurately measure band width and relative amplitudes of various signal components of the transmitted and incoming signals.

The "third method" experimental exciter performed as follows: Referring to Fig. 8, the suppressed carrier at  $f_{c2}$  is nulled out by balancing the two second modulators. No difficulty was experienced in obtaining a null of at least 40 db.,

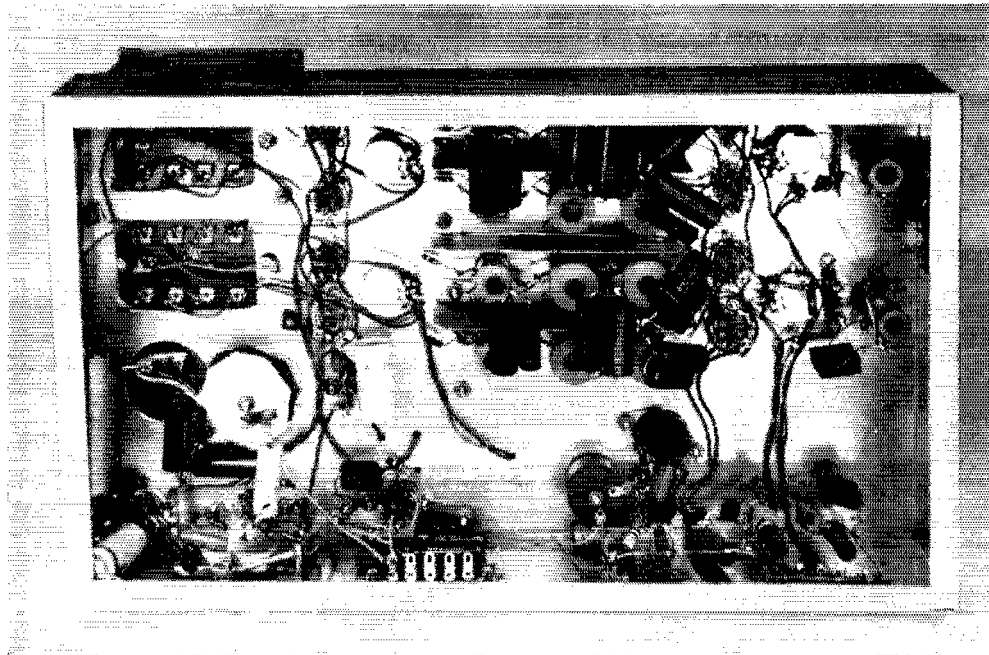

The components clustered at top center are for the low-pass filters.

but any drift in this null results in an audible whistle of 1800 cycles in the received signal.

The carrier-like signals 1800 cycles above and below  $f_{c1}$  are nulled out in the first balanced modulators. Again, there was no trouble in obtaining a null. This null holds better, but the null for both signals didn't occur at exactly the same adjustment — a difficulty that was not enough to prevent obtaining a good signal. It may have been due to some peculiarity of this particular unit.

At first, considerable readable signal in the region marked "filter unwanted" was encountered. Experimentation proved that the original simple constant  $k$  low-pass filters were inadequate for obtaining out-of-channel suppression comparable to that of conventional rigs. Adding a capacitor across the center coil of the filter, to give one  $m$ -derived section, gave vastly improved results, but a better filter designed for sharpest possible cutoff is desirable. Although it is fairly easy to get the desired selectivity at this frequency, the actual slope (in cycles) must be as good as for any conventional filter rig.

When the out-of-channel problem was licked, the phasing aspect was studied. It is extremely interesting to note the effect of differing levels of folded-back side band upon wanted signal intelligibility and distortion. With no suppression of one side band, either signal can be copied, but through fairly heavy interference from the other. Thanks to the inversion of the folded-back side band and the effects of product detection, surprisingly large amounts of unwanted signal can be tolerated without causing undue trouble. When the folded side band is suppressed

20 db. or more it seems to practically disappear as a factor in intelligibility. At 30 db. its effects on voice quality are negligible.

### Conclusions

Many contacts were made using this exciter. The results were excellent. Although all desired adjustments and investigations are not complete some conclusions can be drawn from the work done.

The system is basically capable of producing excellent s.s.b. signals. Although these signals are actually double-side-band suppressed-carrier, the side-band components are so arranged that they tune like and are otherwise indistinguishable from regular single-side-band suppressed-carrier transmissions. Although the system benefits from the extremely low frequency of filter operation, and poor phasing is not ruinous, the actual attenuation vs. frequency of the two filters must be as good as in any filter rig.

The big obstacle, at the present state of design, is the complete dependence upon maintaining the null in the balanced modulators to remove the carrier and its resulting audible beat.

Although it can not be foretold what, if any, part the "third method" will play in future s.s.b. voice communication, this article is presented because this system should intrigue anyone interested in the various types of modulation.

I wish to thank those on the 75-meter band whose parts, interest, and encouragement made this an enjoyable project. The charts and graphs accompanying this article were largely prepared by Tony Sivo, W2FYT, as a result of early discussions concerning the "third method."

### Silent Keys

It is with deep regret that we record the passing of these amateurs:

- W1AKU, Gordon S. Dayton, Winsted, Conn.
- W1DDG, Hyman Yoffe, Revere, Mass.
- WN1NYS, Ernest W. Sims, Bradford, R. I.
- K2MFD, Leonard E. Park, Long Beach, N. Y.
- W3BCL, Albert Wolni, Pittsburgh, Pa.
- W3AZG, Frederic A. Leonard, Coraopolis, Pa.
- WN3ERT, Warren J. Hunter, Allentown, Pa.
- W4EAK, Walter R. Hinton, jr., Greensboro, N. C.
- W4ABN, James E. Brightwell, Hendersonville, N. C.
- ex-W4ATS, Harry W. Schiffman, Greensboro, N. C.
- W5AFG, Elmer J. White, Beaumont, Texas
- W6BLY, Ira J. Schab, Whittier, Calif.
- K6DTO, Gilbert L. Beneze, Hawthorne, Calif.
- W6FMT, Roland W. Davidson, Whittier, Calif.
- W6LEC, Hubert Sherman, Whittier, Calif.
- W7BDP, James H. Foster, Butte, Mont.
- W8WET, John W. Adamson, Port Austin, Mich.
- W9KDL, Leonard L. Schnirring, Sac City, Iowa
- W9FMD, Arnold N. Svarte, Duluth, Minn.
- W9FRE, Everett S. Stokes, Sidney, Nebr.
- W9KTE, Alvis E. Hagans, Norton, Kan.
- W9AFU, David F. Michael, Springfield, Mo.
- Z1IMG, Ernie Parkin, Waieke, N. Z.



September 1932

... "An Intermediate-Frequency and Audio Unit for the Single-Signal Superhet" was the lead-off article 25 years ago, to be used in conjunction with the unit described the previous month.

... The "Thirty-Three Watts per Dollar" rig was also featured in this issue, with W6CUII explaining how to get high output with efficiency and safety from a type '52.

... Another popular article in this issue was the symposium on "Sticks That Have Stuck", being a roundup of various types of masts and an attempt to determine which was best.

... An article about "Science Service Ursigrams" reminds us that cosmic data was being investigated long before the IGY came along.

... In IARU News are reported newly-adopted rules for the issuance of WAC certificates — rules which have continued unchanged to this date. Incidentally, for the first half of 1932 a total of 69 WACs had been issued. That is somewhat under the current rate!

... And there were more reports on the use of 56 Mc. at the National Glider Meet.