

# TIM

## GPS Receiver Macro Component

### Data Sheet

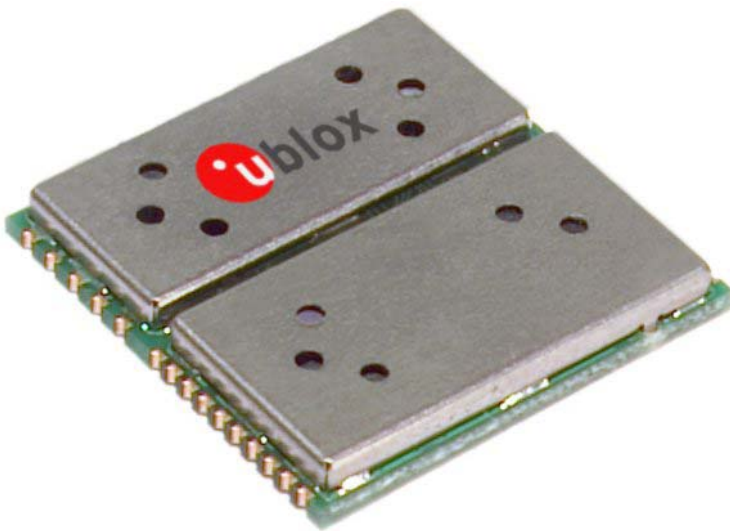

#### Abstract

This document describes the features and specifications of the TIM macro-component, a low power GPS receiver macro-component. Based on the SiRFstar™ II GPS technology, it offers high GPS performance and data logging capabilities.

<b>Title</b>	TIM		
<b>Subtitle</b>	GPS Receiver Macro Component		
<b>Doc Type</b>	Data Sheet		
<b>Doc Id</b>	GPS.G2-MS2-01001-J		
<b>Revision Index</b>	<b>Date</b>	<b>Name</b>	<b>Status / Comments</b>
C	23. Aug 01	PE	
D	3. Sep 01	PE	Updates
E	9. Oct 01	PE	Operating conditions
F	18. Feb 02	PE, GzB, Mvo, TN	General revision, new design guidelines
F1	7. Mar 02	TN	Addition/corrections to active antenna supervisor page
G	26. Apr 02	GzB	New illustrations
H	23. Aug 02	GzB	Updates
I	11. Apr 03	GzB	New CI, corrections in sections 2.2, 3.3 (pin 10), 6 (item 2), minor text corrections
J	30. Oct 03	GzB	Updates in section 4.6

We reserve all rights in this document and in the information contained therein. Reproduction, use or disclosure to third parties without express authority is strictly forbidden.

For most recent documents, please visit [www.u-blox.com](http://www.u-blox.com)

The specifications in this document are subject to change at u-blox' discretion. u-blox assumes no responsibility for any claims or damages arising out of the use of this document, or from the use of modules based on this document, including but not limited to claims or damages based on infringement of patents, copyrights or other intellectual property rights. u-blox makes no warranties, either expressed or implied with respect to the information and specifications contained in this document. u-blox does not support any applications in connection with active weapon systems and ammunition, nor life supporting applications. Performance characteristics listed in this document are estimates only and do not constitute a warranty or guarantee of product performance.

The copying, distribution and utilization of this document as well as the communication of its contents to others without expressed authorization is prohibited. Offenders will be held liable for the payment of damages. All rights reserved, in particular the right to carry out patent, utility model and ornamental design registrations.

u-blox, the u-blox logo and ANTARIS are registered trademarks of u-blox AG. NavLox, FixNOW, EKF and Enhanced Kalman Filter are trademarks of u-blox AG. Other trademarks are property of the respective companies. Copyright © 2003, u-blox AG

# Contents

<b>1</b>	<b>Functional Description</b>	<b>4</b>
1.1	Overview	4
1.2	Block Diagram	4
1.3	Benefits	5
1.4	Features	5
1.5	Operating Modes	6
1.6	Protocols	7
<b>2</b>	<b>Performance Specification</b>	<b>7</b>
2.1	GPS Accuracy	7
2.2	Start-up Times	7
<b>3</b>	<b>Mechanical Specification</b>	<b>9</b>
3.1	Dimensions	9
3.2	Specification	9
3.3	Pinout	10
<b>4</b>	<b>Interface Specification</b>	<b>11</b>
4.1	Serial Interfaces	11
4.2	Reset Pin	11
4.3	Special Boot Pin	11
4.4	PPS Signal	11
4.5	RF Input	12
4.6	Special Power Pins	12
4.7	Active Antenna Supervisor	12
<b>5</b>	<b>Electrical Specification</b>	<b>13</b>
5.1	Absolute Maximum Ratings	13
5.2	Operating Conditions	13
<b>6</b>	<b>External Wiring for minimal Configuration</b>	<b>15</b>
<b>7</b>	<b>Layout</b>	<b>17</b>
7.1	Pad Layout	17
7.2	Layout Recommendations	17
<b>8</b>	<b>Environmental Specification</b>	<b>18</b>
<b>9</b>	<b>Product Lineup</b>	<b>19</b>
9.1	Default Settings	19
9.2	Firmware Updates and Customized Configurations	19
9.3	Ordering Information	19

# 1 Functional Description

## 1.1 Overview

The TIM GPS macro component is a self-contained receiver for the Global Positioning System (GPS). The complete signal processing chain from antenna input to serial output is contained within one single component. The height of 3mm (~120mil) at the size of 25.4mm x 25.4mm (1" x 1") makes it the ideal GPS solution for applications with stringent space requirements. Innovative packaging technology has opened the door for a thin and compact GPS receiver unique on the market. This new type of package makes expensive RF cabling obsolete. Because the RF input is available on a pin, the TIM macro component is SMT solderable and can be handled by standard pick-and-place equipment. TIM is a macro component, which enables a fully automatic assembly process.

TIM provides two serial ports, which can handle NMEA or SiRF® proprietary data format or accept differential GPS data (RTCM).

Operating at a nominal operating voltage of 3.3 Volts, the module consumes less than 0.5 Watts in continuous operation mode. The implementation of the patent pending TricklePower™ Mode allows a considerable reduction of power consumption for applications where power consumption is of primary concern.

Featuring the GRF2 RF front-end chip and an integrated Low-Noise Amplifier (LNA), TIM connects seamlessly to low-cost passive and active antennas. The bias voltage for active antennas can be supplied externally.

## 1.2 Block Diagram

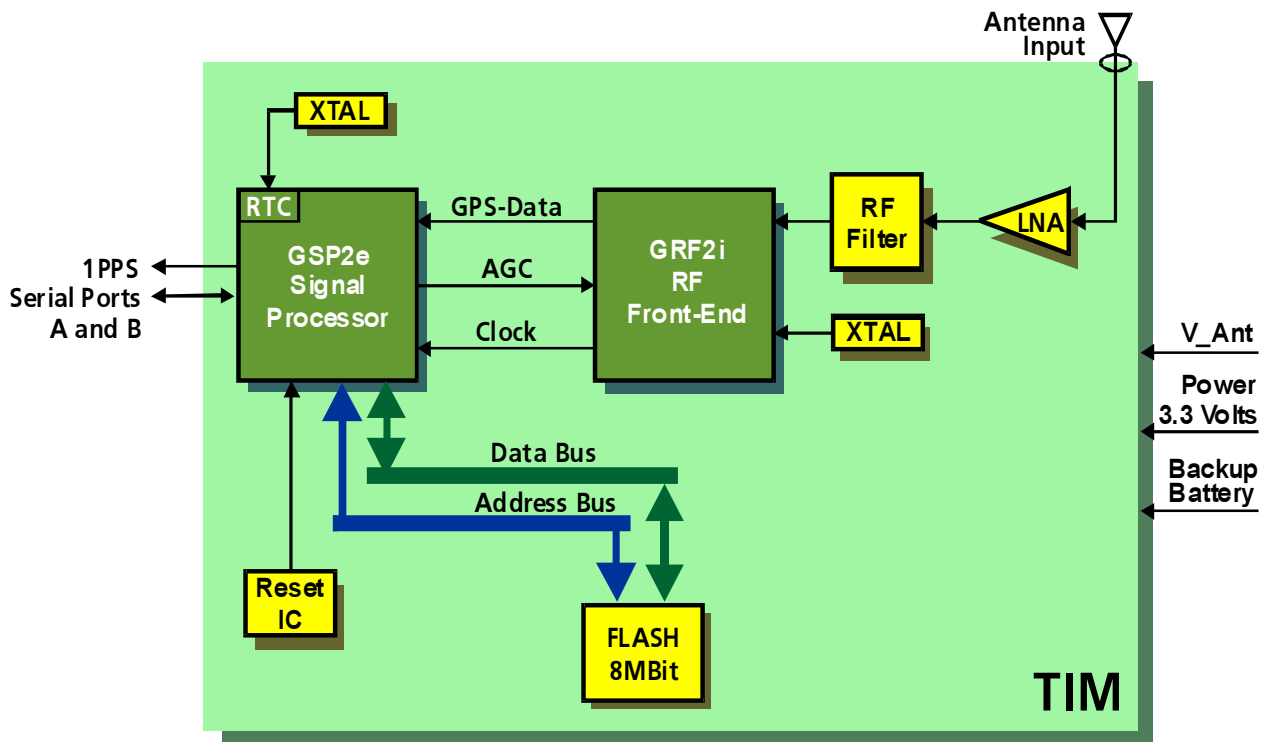

Figure 1: Block Diagram

### 1.3 Benefits

- Fully self-contained GPS receiver (PVT output)
- Low power consumption (max. 0.5 W)
- Excellent GPS performance
  - Fast time-to-first-fix
- Macro component
  - Very compact design
  - Automatic pick and place assembly
  - Reflow solderable
- Supports Satellite Based Augmentation Systems (SBAS)
- Integrated data logging
- Fully EMI shielded
- Passive and active antenna support
- Immune to RF interference

### 1.4 Features

- 12 channel GPS receiver
- 1 Hz position update rate
- SiRFstar™ II architecture
  - GRF2i RF front-end IC
  - GSP2e GPS DSP with integrated Real Time Clock
- 8 MBit FLASH memory
- Low noise amplifier
- Battery voltage supply pin for internal backup memory and real time clock
- Power management features
  - TricklePower™ mode
  - Push-to-Fix™ mode
- Operating voltage 2.75 ... 3.45 V
- Industrial operating temperature range –40...85°C
- Small size
  - Size                    25.4mm x 25.4mm
  - Height                3mm
  - Weight                3g

## 1.5 Operating Modes

Following Operating Modes are supported:

Operating Modes	Description
<b>Continuous Mode</b>	<p>In <i>Continuous Mode</i>, the module is continuously running as long as the operating voltage Vcc is supplied. Position fixes are generated at the maximum update rate. Use of an external backup battery is recommended to reduce the system's startup time. If an external backup battery is connected the module keeps the internal real time clock (RTC) running and holds the SRAM data (ephemeris and almanac data) during power supply interruption. This enables warm- and hot-start. However, under good visibility conditions cold- and warm start times do not differ significantly.</p>
<b>Power Saving Modes</b>	
<b>TricklePower™ Mode</b>	<p>In TricklePower™ Mode, Vcc is continuously supplied to the module. A software configurable internal timer periodically forces the module to acquire a position fix. Between the fixes, the module remains in an ultra-low power sleep mode. This mode is recommended for applications where lowest power consumption and a periodical position up-date are of primary concern. A backup battery must be connected to enable the module to reduce startup times when recovering from a Vcc supply interruption.</p> <p>During the TricklePower™ mode the firmware periodically schedules ephemeris collection and RTC calibration to ensure that useable data is always available. Ephemeris collection occurs typically once within a 30 minutes period and also whenever a new satellite rises above the horizon.</p> <p>The power-on scenario in TricklePower™ Mode differs from the one in Continuous Mode. If the module fails to acquire 3 satellites within a given time (due to bad visibility or very low signal levels) the module goes into an extended sleep phase. <i>MaxOffTime</i> defines the length of this sleep time. After this period the module wakes up and tries to acquire a position fix again.</p> <p>For more detailed information on TricklePower™ Mode please check the <i>TIM Low Power Mode Application Note</i> [2].</p>
<b>Push-to-Fix™ Mode</b>	<p>The Push-to-Fix™ Mode puts the receiver into a background duty cycle mode that provides a periodic refresh of position, GPS time, ephemeris data and RTC calibration. The receiver stays in sleep mode until either an external reset or the expiration of the <i>Push-to-Fix-Period</i> wakes it up for a position update. Ephemeris data is automatically updated whenever necessary.</p> <p>The time to first fix stays under 8 seconds if the receiver performed a successful position fix in the last cycle (i.e. within the last ephemeris update phase).</p> <p>For more detailed information on Push-to-Fix™ Mode please check the <i>TIM Low Power Mode Application Note</i> [2].</p>

**Table 1: Operating Modes**

## 1.6 Protocols

The TIM supports different serial protocols.

Protocol	Type	Runs on
NMEA	Input/output, ASCII, 0183	All serial ports
SiRF <sup>®</sup> Binary	Input/output, binary	All serial ports
RTCM	Input Message 1,2,3,9	All serial ports

**Table 2: Available Protocols**

For specification of the various protocols see the *Protocol Specification* [3].

# 2 Performance Specification

## 2.1 GPS Accuracy

GPS receiver accuracy is a function of GPS receiver performance, satellite visibility of the antenna, satellite constellation and Selective Availability (SA). GPS accuracy is not properly defined. Every manufacturer uses own means of defining, measuring and calculating position accuracy. On May 1, 2000 the US president decided to discontinue SA with immediate effect. This improves GPS accuracy dramatically without any modification on the receivers. See the *TIM Navigation Performance Application Note* [1] for more details on static and dynamic performance characteristics.

## 2.2 Start-up Times

A GPS receiver has different start-up scenarios, which differ significantly in the Time-to-first-fix (TTFF). These start-up scenarios depend on the amount of knowledge the GPS receiver has regarding its position and the availability of satellites. Just like GPS accuracy, startup times for GPS receivers are another field where every manufacturer has its own naming scheme, and therefore, comparison between receivers is difficult. In the following a short introduction to our definitions of start-up times (see Table 3 for specifications) is given. Please note that these numbers were measured with good visibility (open view to the sky). Obstructed view will result in longer start-up times.

Definitions of Start-Up Modes:

- Cold Start**            In Cold Start scenario, the receiver has no knowledge on last position, approximate time or satellite constellation. The receiver starts to search for signals blindly. This is standard behavior, if no backup battery is connected.
- Cold Start time is the longest startup time for u-blox GPS receivers.
- Warm Start**            In Warm Start scenario, the receiver knows its last position, approximate time and almanac which are stored in battery-backed RAM. Thanks to this, it can quickly acquire satellites and get a position fix faster than in cold start mode.
- Hot Start**              In Hot Start Scenario, the receiver- with a backup battery - was off for less than 2 hours. It uses its last Ephemeris data to calculate a position fix.
- Reacquisition**        The reacquisition figure gives the time required to get lock on a satellite if the signal has been blocked for a short time (e.g. due to buildings). This is most important in urban areas. Reacquisition time is not related with TTFF.

Parameter	Specification	
Receiver Type		L1 frequency, C/A Code, 12-Channels
Max Up-date Rate		1 Hz
Accuracy (Selective Availability off)	Position	4 m CEP <sup>1</sup>
	Position DGPS	<2 m CEP <sup>2</sup>
Acquisition	Cold Start	45 s (typical)
	Warm Start	38 s (typical)
	Hot Start	2-8 s (typical)
Signal Reacquisition		100 ms
Dynamics		< 4 g
Operational Limits		COCOM restrictions

**Table 3: Performance Specification**

<sup>1</sup> CEP = Circular Error Probability: The radius of a horizontal circle, centered at the antenna's true position, containing 50% of the fixes.

<sup>2</sup> Depends on accuracy of DGPS system



### 3 Mechanical Specification

#### 3.1 Dimensions

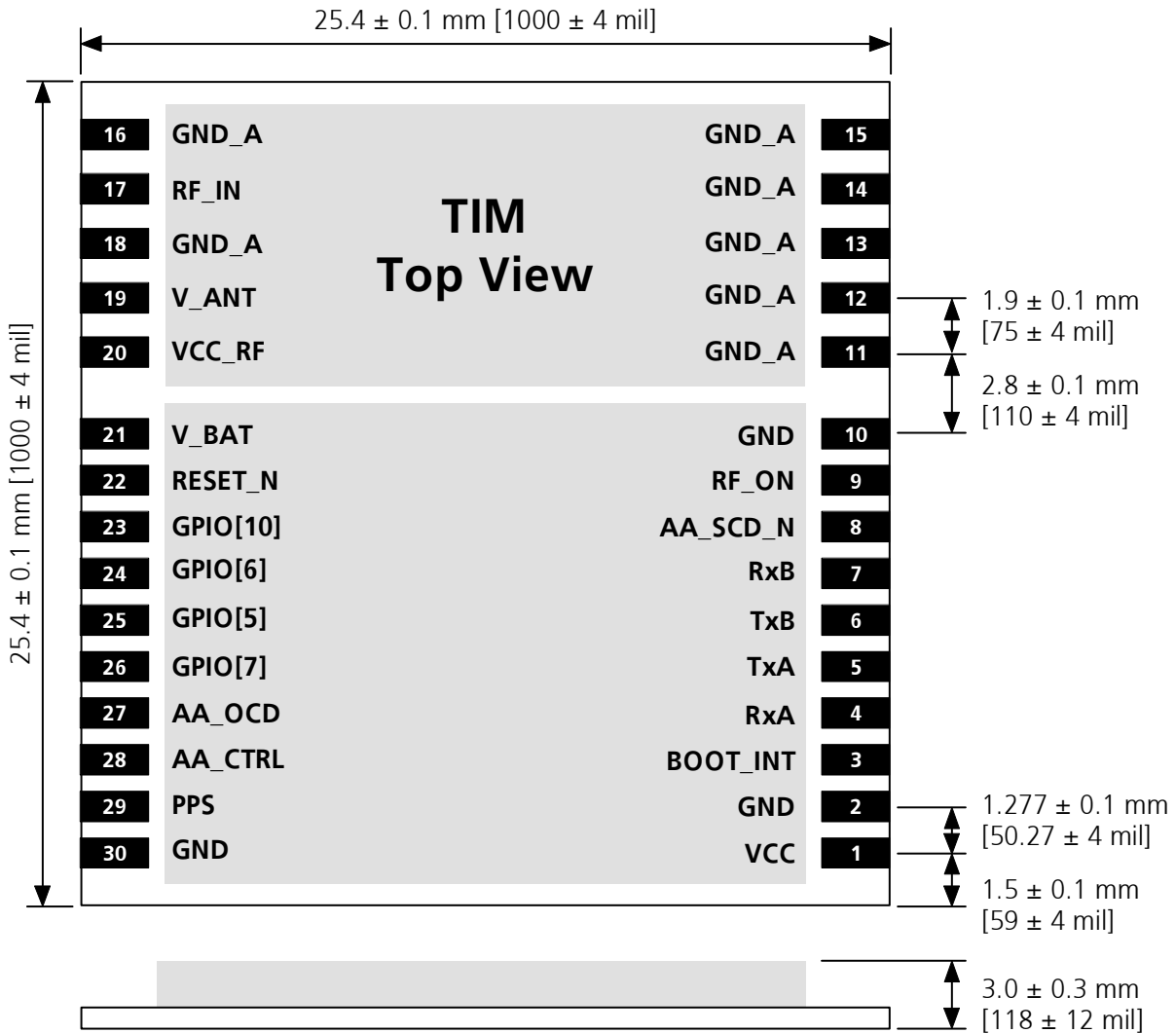

Figure 2: TIM Dimensions

#### 3.2 Specification

Parameter	Specification	Tolerance	Unit
Length	25.4	±0.1	mm
Width	25.4	±0.1	mm
Thickness	3.0	±0.3	mm
Pitch RF pins	1.9	±0.1	mm
Pitch Digital pins	1.277	±0.1	mm
Weight	3		g

Table 4: Mechanical Specification

### 3.3 Pinout

Standard Function				Remarks
Pin	Name	I/O	Description	
1	VCC	I	Supply voltage	
2	GND	I	Digital Ground	
3	BOOT_INT	I	Boot mode	Leave open if not used (normal operation) Module boots in debug mode if high during reset
4	RxA	I	Serial Port A	Pull up if not used
5	TxA	O	Serial Port A	Leave open if not used
6	TxB	O	Serial Port B	Leave open if not used
7	RxB	I	Serial Port B	Pull up if not used
8	AA_SCD_N	I	Active antenna short circuit detection	0 = short circuit, 1 = no short circuit Leave unconnected if not used
9	RF_ON	O	Indicates power state of RF part	High if VCC_RF is on
10	GND	I	Digital Ground	Recommended to leave this pin unconnected (Will be reserved for future uses)
11 – 16	GND_A	I	Analog Ground	
17	RF_IN	I	GPS signal input	50 Ohms @ 1.575GHz, apply no DC through this pin
18	GND_A	I	Analog Ground	
19	V_ANT	I	Antenna Bias voltage	Leave unconnected if not used
20	VCC_RF	O	Output Voltage RF section	May be connected to V_ANT
21	V_BAT	I	Backup voltage supply	Connect to GND if not used
22	RESET_N	I	Reset (Active low)	Leave open if not used
23	GPIO[10]	I	General-purpose I/O	For use with data logging. Leave open if not used
24	GPIO[6]	I/O	General-purpose I/O	For use with data logging. Leave open if not used
25	GPIO[5]	I/O	General-purpose I/O	For use with data logging. Leave open if not used
26	GPIO[7]	I/O	General-purpose I/O	For use with data logging. Leave open if not used
27	AA_OCD	I	Active Antenna open circuit detection	(1 = open circuit, 0 = no open circuit) Leave unconnected if not used
28	AA_CTRL	O	Active antenna control	(0 = turned off, 1 = turned on) Leave unconnected if not used
29	PPS	O	One pulse per second	Leave open if not used
30	GND	I	Digital Ground	Recommended to leave this pin unconnected (Will be reserved for future uses)

**Table 5: Signals and Module Interface**

## 4 Interface Specification

### 4.1 Serial Interfaces

The TIM GPS receivers provide two serial ports. All serial interface signals (Port A: **TxA**, **RxA**; Port B: **TxB**, **RxB**) operate on 3.3V CMOS and 5V TTL compatible signal levels. External line transceivers (e.g. MAX3232) are necessary to provide RS 232 compatible signal levels.

Proprietary NMEA and SiRF<sup>®</sup> input messages are available to configure the serial ports, in particular the baud rates. Details on NMEA and SiRF<sup>®</sup> binary protocol messages are summarized in the *TIM Protocol Specification* [3].

Baud Rate	Comments
1200	NMEA, suitable for RMC message only
2400	NMEA, suitable for RMC message only
4800	Must deactivate some messages to avoid communication bottleneck and loss of information, e.g. NMEA: RMC and ZDA only
9600	Minimum recommended baud rate for NMEA output in standard configuration
19200	Minimum recommended baud rate for SiRF <sup>®</sup> Binary Protocol output
38400	Minimum recommended baud rate for SiRF <sup>®</sup> Binary Protocol output including development data and raw tracking data.
57600	

**Table 6: Supported Baud Rates**

**!** **Attention:** Pull-up unused **RxA** / **RxB** pins to avoid random input caused by a floating state.

### 4.2 Reset Pin

An external reset is initiated by pulling **RESET\_N** low for at least 1 $\mu$ s. If not used, **RESET\_N** can be left unconnected since there is an internal 20k pull-up resistor. **RESET\_N** is also used in Push-to-Fix<sup>™</sup> mode in order to wake up the unit and request a position fix. Minimum pulse width is 1 $\mu$ s.

### 4.3 Special Boot Pin

The boot signal **BOOT\_INT** forces the TIM into special debug mode when restarted with a reset signal or power-up. If not used, **BOOT\_INT** can be left unconnected since there is an internal 1k pull-down resistor.

Starting with firmware revision "Cnnn", the firmware download can also be initiated with proprietary SiRF<sup>®</sup> Binary and NMEA messages.

**!** **Attention:** In order to ensure secure Flash Reprogramming, make sure that the signal **BOOT\_INT** is available on jumper. Details on special boot and firmware upgrade procedures are summarized in the *TIM Firmware Update Utility - User's Manual* [4]

### 4.4 PPS Signal

A one-pulse-per-second active-high signal is output on pin **PPS**. This signal is 3.3V CMOS and 5V TTL compatible. In low power modes the **PPS** signal is disabled (75 k pull-down resistor).

## 4.5 RF Input

Due to the RF characteristics of I/O pins of the TIM macro component, it is possible to have the RF input routed to a pin. This makes expensive RF connectors and cabling obsolete.

Using a passive antenna setup, TIM connects seamlessly to the antenna structure. The connection to the antenna is directly routed to **RF\_IN** (pin 17) on the PCB. Using an active antenna the **RF\_IN** pin of the TIM is routed to an RF connector on the PCB.

However due to the RF characteristics of the signal the design has to fulfil certain criteria. The line on the PCB from the antenna (or antenna connector) has to be a controlled impedance line (e.g. Microstrip at 50  $\Omega$ ).

**! Attention:** If the **RF\_IN** pin is routed to an RF connector, an appropriate ground plane for the microstrip line is required!

## 4.6 Special Power Pins

A DC-bias voltage can be supplied to an active antenna via pin **V\_ANT**. The bias voltage is internally fed into the **RF\_IN** pin. Typically, the voltage required by an active antenna is 3.3V or 4.5V. **VCC\_RF** can be used to power an external active antenna (**VCC\_RF** connected with **V\_ANT**) provided the antenna consumes less than *Irf\_out* and supports an input voltage of *Vcc\_RF - V\_ant\_drop* (Parameters in *italic* are described in Table 8). In TricklePower™ and Push-To-Fix™ modes, **VCC\_RF** is switched off during sleep mode.

**! Attention:** The TIM contains no short-circuit protection. External circuitry is needed for this to prevent high current flows through the module to the antenna.

If a passive antenna is used, no bias voltage needs to be provided and this pin should be left open.

**! Attention:** Noise on the antenna bias voltage will degrade the GPS performance of the TIM.

An external backup battery has to be connected to pin **V\_BAT** to enable RTC operation and SRAM backup and to allow GPS warm or hot starts after power supply interruption. Connect **V\_BAT** to GND if no battery is used. The use of supercaps to provide the battery backup supply is only recommended if an external circuit ensure **V\_BAT** is pulled to GND when the supercap is discharged to a voltage level below the specified minimum value.

**! Attention:** If not grounded, the voltage level to **V\_BAT** must be maintained above the minimum specified level all times. A voltage level below, even for short time periods, will result in loss of date, time and other retained GPS information.

## 4.7 Active Antenna Supervisor

The TIM provides three pins to communicate with a controlled voltage supply circuit for providing power to active antennas. Active antennas are understood as antennas with own low noise amplifiers where the supply voltage is provided in form of a DC bias to the antenna. The active antenna supervisor is a part of the firmware running on the TIM module. It is able to detect and report short and open circuits (**AA\_SCD\_N**, **AA\_OCD**), and is able to shut off the antenna supply using the **AA\_CTRL** output. The supply will shut off automatically when a short circuit has been detected and remains off until the next reset. The supervisor is disabled by default, but can be activated during firmware download. The user parameters, SiRF<sup>®</sup> binary and NMEA messages with status information on the active antenna supervisor are documented in the *TIM Protocol Specification* [3].

An external circuit is necessary to complete the active antenna supervisor. It is described in the *TIM Active Antenna Supervisor Application Note* [6].

**! Attention:** This supervisor has no impact on **V\_ANT**. Do not feed **AA\_CTRL** back into **V\_ANT** directly.

## 5 Electrical Specification

### 5.1 Absolute Maximum Ratings

Parameter	Symbol	Min	Max	Units
Power Supply Voltage	Vcc	-0.3	3.6	V
Input Pin Voltage (all except RESET_N)	Vin	-0.3	5.0	V
Input Pin Voltage of RESET_N	Vin	-0.3	Vcc + 0.3	V
Antenna Bias Current	Iant		300	mA
Storage Temperature	Tstg	-40	125	°C

Table 7: Absolute Maximum Ratings

**! Warning** Stressing the device beyond the “Absolute Maximum Ratings” may cause permanent damage. These are stress ratings only. TIM is not protected against overvoltage or reversed voltages. If necessary, voltage spikes exceeding the power supply voltage specification, given in table above, must be reduced by using appropriate protection diodes.

### 5.2 Operating Conditions

Parameter (See <sup>1</sup> )	Symbol	Condition	Min	Typ	Max	Units
Power Supply Voltage	Vcc		2.75 (See <sup>2</sup> )	3.3	3.45	V
Power Supply Voltage Ripple	Vcc_PP			50 (See <sup>2</sup> )		mV
Backup Battery Voltage	V_bat		1.85		3.6	V
Input Pin Voltage	Vin		0		5.0	V
Input Pin Voltage (low)	Vin_low				0.3 x Vcc	V
Input Pin Voltage (high)	Vin_high		0.7 x Vcc			V
Antenna bias voltage	V_ant				12	V
Antenna bias voltage drop	V_ant_drop	50mA		0.2		V
Sustained Supply Current (See <sup>3</sup> )	Icc	Vcc = 3.3V		160		mA
		Vcc = 2.8V		135		mA
Peak Supply Current (See <sup>3</sup> )	Iccp	Vcc = 3.3V		210		mA
		Vcc = 2.8V		170		mA
Vcc_RF output current	Irf_out				25	mA
Vcc_RF voltage	Vcc_RF	Irf_out = 25mA		Vcc-0.1		V
TricklePower™ Sleep Mode Supply Current	Itps	Vcc = 3.3V		240		uA
		Vcc = 2.8V		215		uA
Standby Battery Current	Ibat	V_bat = 3.3V		4.5		uA
Operating Temperature	Topr		-40		85	°C

<sup>1</sup> An ambient temperature of 25°C is assumed.

<sup>2</sup> **Attention! The minimum supply voltage (2.75V) minus maximum ripple voltage (50mV) equals to the absolute minimum supply voltage at the module (2.70V)!**

A lower voltage will immediately activate a reset. Make sure your design provides a voltage safety margin to avoid dropping below 2.7V at highest instantaneous current draw.

<sup>3</sup> During highly active CPU phases, the peak level may endure for several hundred milliseconds. Use the "Peak Supply Current" (Iccp) to dimension your power supply circuit. Use the "Average Supply Current" (Icc) for battery capacity budget calculations.

Table 8: Operating Conditions

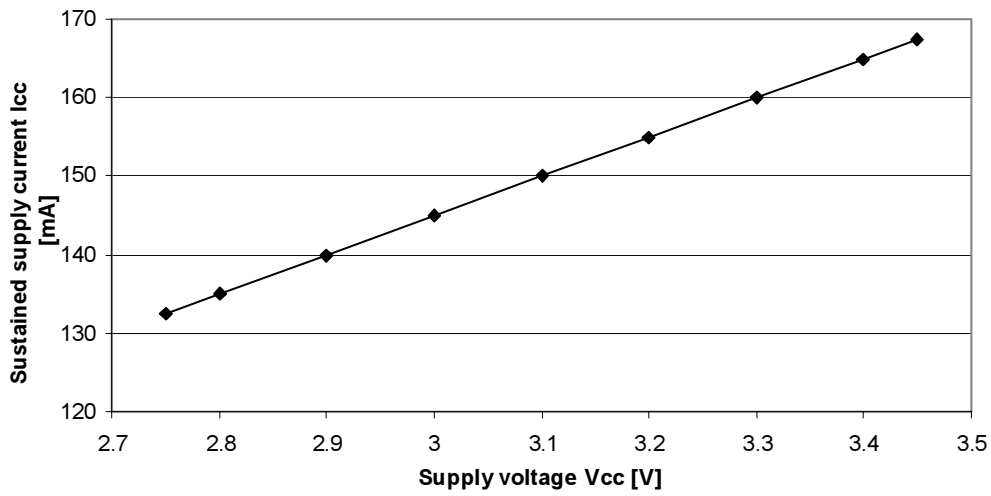

Figure 3: Supply current versus supply voltage

Operation beyond the "Operating Conditions" is not recommended and extended exposure beyond the "Operating Conditions" may affect device reliability.

## 6 External Wiring for minimal Configuration

The following are the minimum outside connections one has to provide to allow basic operation of TIM.

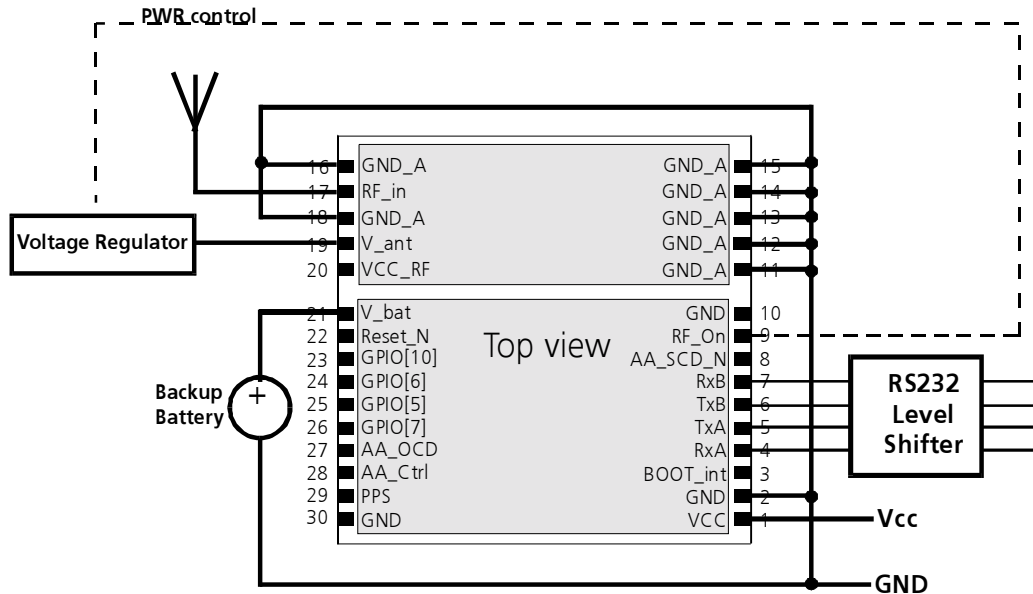

Figure 4: Minimal External Wiring

1. **Antenna:** The connection to the antenna has to be routed on the PCB. Use a controlled impedance line (microstrip) to connect **RF\_IN** to the antenna or antenna connector.
2. **Power** Connect Vcc pin to 3.3V. And, connect GND pins 2, 11-16, and 18 to ground. Leave ground pins 10 and 30 open. The power supply should be capable of delivering a sustained current of at least 210 mA. A proper RESET signal is internally generated.
3. **Serial Interface** Pins **TxA**, **TxB**, **RxA** and **RxB** are 3.3V CMOS and 5V TTL compatible. If you need different voltage levels, use appropriate level shifters, e.g. MAX3232 from Maxim or equivalent in order to obtain RS-232 compatible levels. Pull-up unused RX inputs.

4. **Active Antenna Bias Voltage:** If you intend to use an active antenna, supply the required bias voltage to pin **V\_ANT**. Make sure that this voltage is properly filtered to avoid injection of noise into the RF-frontend. If your environment is very noisy, a low-noise voltage regulator such as National LP2988, LP2982 or Analog Devices ADP 3307 might be needed to reduce voltage ripple. For maximum power savings in TricklePower™ mode also the antenna bias voltage should be switched. The **RF\_ON** signal can be used to control the voltage regulator for the antenna bias voltage.

**VCC\_RF** can be used to power an external active antenna (**VCC\_RF** connected to **V\_ANT**) if the antenna consumes less than  $I_{rf\_out}$  and supports an input voltage of  $V_{cc\_RF} - V_{ant\_drop}$  (Figure 5).

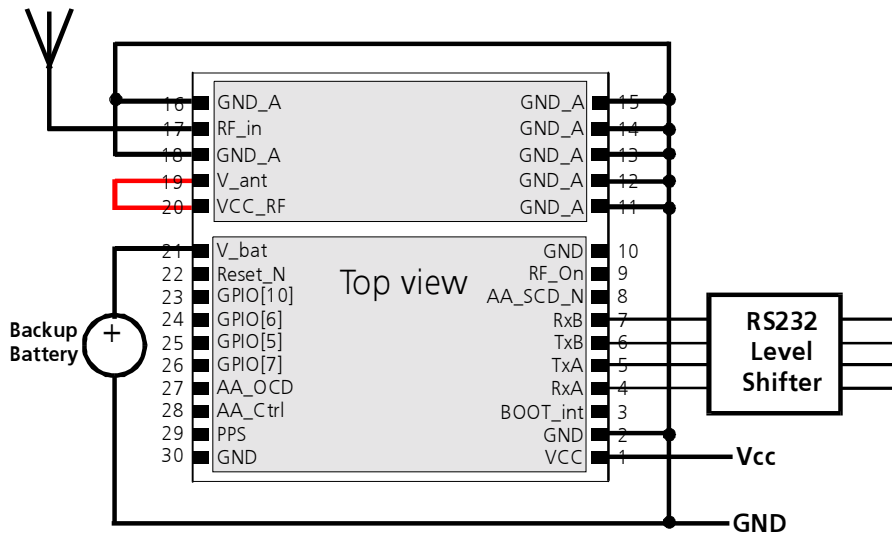

Figure 5: Minimal External Wiring, with Internal Antenna Power

5. **Backup Battery:** It is recommended to connect a backup battery to **V\_BAT** in order to enable the Warm and Hot Start features of the receivers. If you don't intend to use a backup battery, connect this pin to GND.
6. **1PPS Signal:** A one-pulse-per-second signal is available through output pin **PPS**.

Leave all unused pins open, if not specified otherwise. That's all.



# 7 Layout

## 7.1 Pad Layout

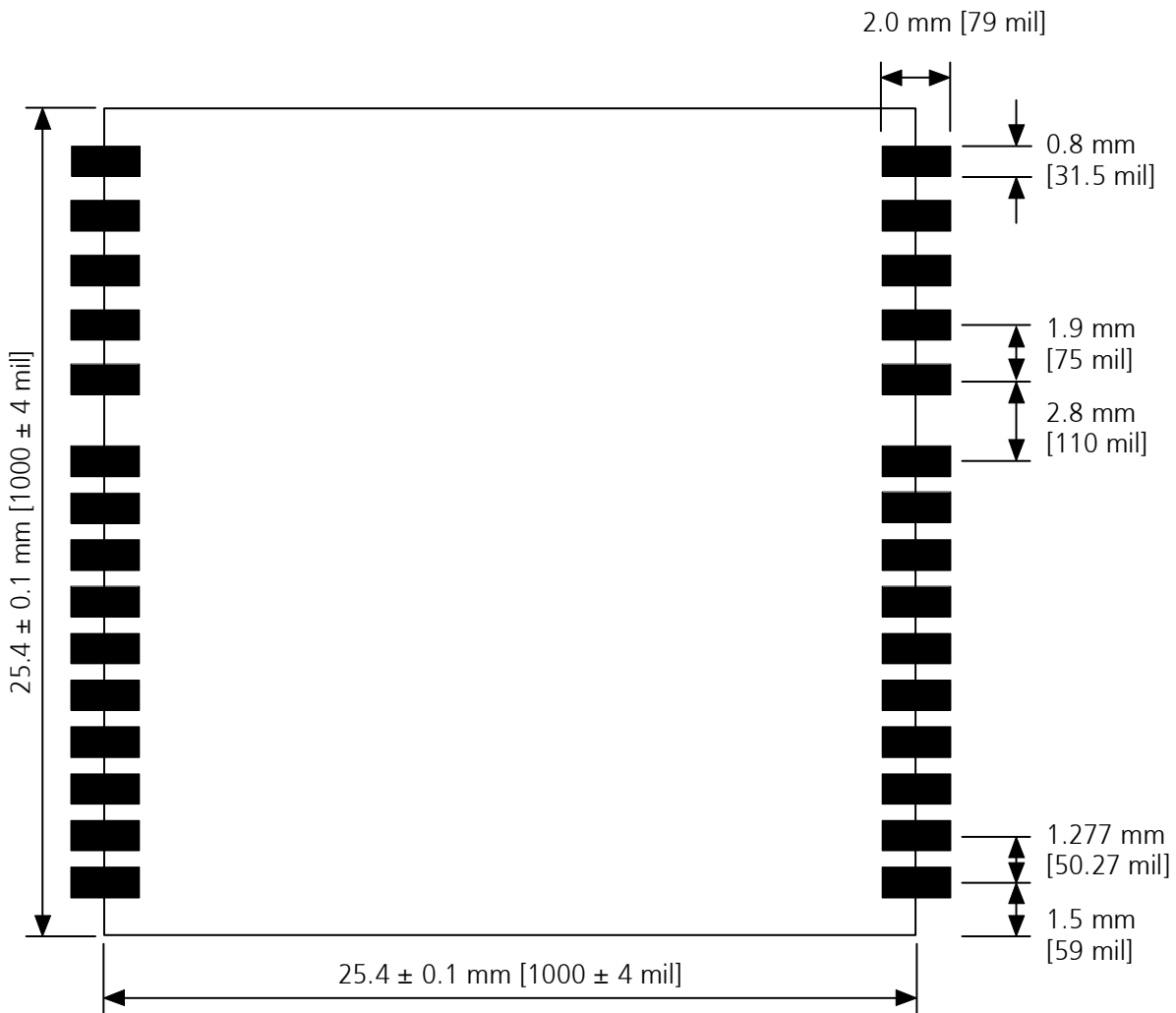

Figure 6: Pad Layout

## 7.2 Layout Recommendations

Please refer to *Application Note on RF and Layout* [8].

## 8 Environmental Specification

Detailed description of the test series:

Test	Standard
Visual inspection	IPC-A-610 "Acceptability of electronic assemblies" I.T.R.I. Publication No. 700 IPC-SM-840B Class 2.
Thermal shock	-40°C...+125°C
Function at various temperatures	-40°C/2 hours; RT/2 hours; +85°C/2 hours; function tests at stable temperature
Lifespan test	+85°C/1000 hours; function
Damp heat, cyclic	+25°C...+55°C; >90% rH
Vibration	10-500 Hz; 2 hours/axis; 5g; function
Shock	30g/11ms (halfsine); 3 Shock/axis; no function
Metallographic investigations	IPC-QE-650

**Table 9: Environmental Specification**

## 9 Product Lineup

### 9.1 Default Settings

Interface	Settings
Serial Port 1 Output	9600 Baud, 8 bits, no parity bit, 1 stop bit Configured to transmit NMEA messages with checksum enabled: <b>GLL, GGA, RMC, VTG, GSV, GSA</b> Additional messages can be activated with appropriate input messages.
Serial Port 1 Input	9600 Baud, 8 bits, no parity bit, 1 stop bit Accepts NMEA messages. Messages and switchover to SiRF <sup>®</sup> binary protocol can be activated with appropriate input messages.
Serial Port 2 Output	No protocol activated. Messages can be activated with appropriate input messages.
Serial Port 2 Input	9600 Baud, 8 bits, no parity bit, 1 stop bit Configured to receive RTCM (messages 1,2,3,9)

**Table 10: Available Protocols**

### 9.2 Firmware Updates and Customized Configurations

Different start-up configuration can be set by reflashing the firmware with different default settings, e.g. NMEA protocol on port A, different update rates, data output via serial port B, etc or to enable the active antenna supervisor status message.

The Firmware Update Utility, described in [4] is a free tool available in the TIM Evaluation Kit (see [5]) and downloadable from the u-blox website. It enables convenient downloads of new firmware and modification of configuration.

### 9.3 Ordering Information

Ordering No.	Product
TIM-ST-0-000-0	TIM TIM GPS Receiver Macro Component Single samples
TIM-ST-0-000-1	TIM TIM GPS Receiver Macro Component Tape on reel 100pcs
TIM-ST-0-000-5	TIM TIM GPS Receiver Macro Component Tape on reel 500pcs

**Table 11: Ordering Information**

Parts of this product are patent protected.

## Related Documents

- [1] TIM Navigation Performance Application Note, GPS.G2-X-01001
- [2] TIM Low Power Modes - Application Note GPS.G2-X-02003
- [3] TIM GPS Receiver - Protocol Specification - Application Note, GPS.G2-X-01003
- [4] TIM Firmware Update Utility - User's Manual, GPS.G2-SW-02004
- [5] TIM Evaluation Kit - User's Guide, GPS-EK-01001
- [6] TIM Active Antenna Supervisor Application Note, GPS-G2-X-02009
- [7] The GPS Dictionary, GPS-X-00001
- [8] TIM RF and Layout Application Note, GPS.G2-X-02005
- [9] TIM Product Quality Application Note, GPS.G2-X-02006

All these documents are available on our homepage (<http://www.u-blox.com>).

## Contact

For further info, please contact us:

Headquarters	Subsidiaries	
<b>u-blox AG</b> Zuercherstrasse 68 CH-8800 Thalwil Switzerland  Phone: +41 1 722 74 44 Fax: +41 1 722 74 47 E-mail: <a href="mailto:info@u-blox.com">info@u-blox.com</a> <a href="http://www.u-blox.com">www.u-blox.com</a>	<b>u-blox Deutschland GmbH</b> Berliner Ring 89 D-64625 Bensheim Germany  Phone: +49 (0) 6251 17566-0 Fax: +49 (0) 6251 17566-11 E-mail: <a href="mailto:info_de@u-blox.de">info_de@u-blox.de</a> <a href="http://www.u-blox.de">www.u-blox.de</a>  <b>Technical Support:</b> Phone: +41 1 722 74 74 E-mail: <a href="mailto:support_de@u-blox.de">support_de@u-blox.de</a>	<b>u-blox Europe Ltd.</b> Barham Court, Teston Maidstone, Kent ME18 5BZ United Kingdom  Phone: +44 1622 618628 Fax: +44 1622 618629 E-mail: <a href="mailto:info_uk@u-blox.co.uk">info_uk@u-blox.co.uk</a> <a href="http://www.u-blox.co.uk">www.u-blox.co.uk</a>  <b>Technical Support:</b> Phone: +44 1622 618628 E-mail: <a href="mailto:support_uk@u-blox.co.uk">support_uk@u-blox.co.uk</a>
	<b>u-blox Asia Pacific Ltd.</b> Suite A, 8/F, Block 7 398 Castle Peak Road Tsuen Wan, Hong Kong  Phone: +852-2940-0085 Fax: +852-2615-2285 E-mail: <a href="mailto:info_ap@u-blox.com">info_ap@u-blox.com</a> <a href="http://www.u-blox.com">www.u-blox.com</a>	<b>u-blox America, Inc.</b> 13800 Coppermine Road Herndon, VA 20171 USA  Phone: +1 (703) 234 5290 Fax: +1 (703) 234 5770 E-mail: <a href="mailto:info_us@u-blox.com">info_us@u-blox.com</a> <a href="http://www.u-blox.us">www.u-blox.us</a>  <b>Technical Support:</b> Phone: +1 (703) 234 5290 E-mail: <a href="mailto:support_us@u-blox.us">support_us@u-blox.us</a>
	<b>u-blox Beijing Office</b> c/o Beijing Eastar Technology Co., Ltd. Suite Z, No. 10 Haidian District, Beijing 100088 P. R. China  Phone: +86-10-6226-2091 Fax: +86-10-6223-4821 E-mail: <a href="mailto:info_ap@u-blox.com">info_ap@u-blox.com</a> <a href="http://www.u-blox.com">www.u-blox.com</a>  <b>Technical Support:</b> Phone: +852-2569-7974 E-mail: <a href="mailto:support_ap@u-blox.com">support_ap@u-blox.com</a>	